



AIR N ARC 300 COMPACT



Lower Profile for Greater Mounting Flexibility!

While keeping full functionality of five power sources in one unit and the capability of multi-functioning, the Air N Arc® 300 Compact All-in-One Power System® was designed to be mounted under a box type body. Coming in 7.5 inches shorter and up to 100 Lbs. lighter than the standard Air N Arc 300 with fuel tank, the new compact unit provides the flexibility and space-saving capability to mount the unit outside the body of the vehicle while still maintaining ground clearance.



SPECIFICATIONS	
Engine	26.5 HP Kohler®, Air Cooled
Air Compressor	Rotary Screw, 150 PSI, 40 CFM (175 MAX PSI)
Generator	7 kW Peak / 6.8 kW Continuous, AC Power, 60 Hz, Single Phase, 120V and 240V Outlets
Welder	High Frequency DC welding, 270 AMPS at 100% Duty Cycle CC: 40-300 AMPS Operating Range, CV: 15-30 Volts
Battery Charger/Booster	300 AMPS 12V/24V Boost, 50 AMP 12V Charge
Drive System	Belt Driven
Fuel Capacity	Tied to Chassis

Air N Arc® 300 Compact Gas Unit Dimensions with Fittings (In.): 47.1L x 24.6W x 23.9H
Foot Print (In.): 47.1L x 21.5W x 23.9H
Dry Weight (Lbs.): 650

AIR NARC® 300 COMPACT

FEATURES

- True Two Generator System for Safe Multi-Function of Welder and Electric tools
- All the Benefits of a High Frequency Welder Offering Excellent Weld Characteristics
- 40 CFM Rotary Screw Compressor for Air on Demand and Extended Life of Unit
- Heavy Duty Belt Drive System for Anti-Vibration and Long Service Intervals
- Remote Mount Control Panel for the Ultimate in User Convenience
- Fuel System Integrated with the Chassis
- Integrated Lift Hook and Battery Tray
- Designed for Easy Maintenance
- Small Footprint - Will Fit on Side Pack or Behind Cab or Under Box Type Body
- Powder Coated Sheet Metal
- Galvannealed Steel
- Low Profile Height

AIR COMPRESSOR

- Encapsulated Rotary Screw Compressor for Air-On-Demand
- 40 CFM @ 150 PSI
- 175 Max PSI

WELDER

- High Frequency DC Welding
- 270 AMPs at 100% Duty Cycle
- CC Range 40 – 300 AMPs Operating Range
- CV Range 15 – 30 Volts
- Independent DC Welder
- Auto Speed Control
- CV MIG Capabilities

GENERATOR

- 7 kW Peak / 6.8 kW Continuous @ 60 Hz (Available In 5.7 kW Continuous Watts @ 50 Hz)
- Independent AC Generator
- Brushless
- Smooth Wave for Minimal Distortion
- Two-120V Outlets and One-240V Outlet

BATTERY BOOST/CHARGE

- 300 AMP 12V/24V Boost
- 50 AMP 12V Charge

REMOTE CONTROL PANEL

- Provides User Convenience and Safety
- All Functions are Accessible at Panel, No Need to Jump In and Out of Vehicle

COLD WEATHER PACKAGE

- Optional 12V Heaters

ENGINE

- 26.5 HP EFI Kohler®, Air Cooled or 25 HP Kubota®, Liquid Cooled
- Electric Start
- Provides Power for Emergency and Safety Lights with Truck Engine Turned Off
- Tier 4 Emission Compliant
- Automatic Glow Plugs

OPTIONS/ACCESSORIES

- Welding Cables - 25', 50'
- Welding Helmet with Auto Darkening Lens
- Battery Booster Cables
- Cable Extension Segment
- Fuel Tank – Slimline 11 Gallon
- Remote Air Tanks
- Maintenance Kits
- Cold Weather Kits
- GFCI Kit Available

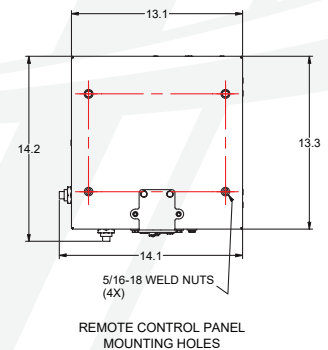
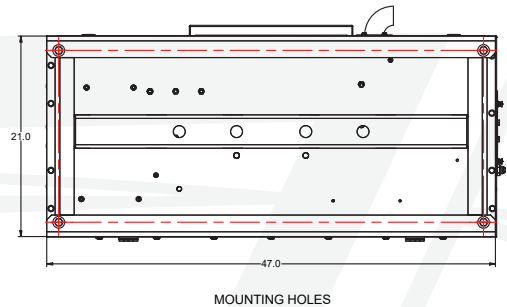
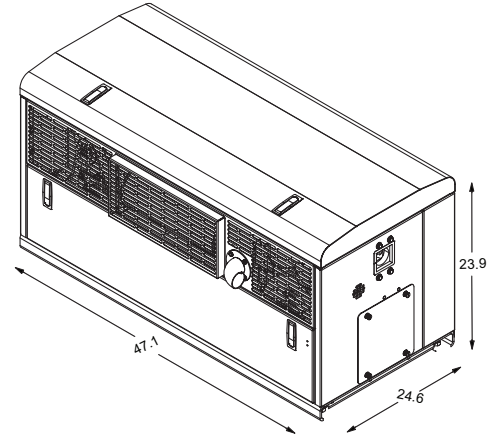

Vanair reserves the right to make changes in engineering, design, and specifications; add improvements; or discontinue manufacturing at any time without notice or obligation. Vanair, the Vanair logo and MOBILE POWER SOLUTIONS are registered trademarks or trademarks of Vanair Manufacturing, Inc., Michigan City, IN, USA. © 2021 All Rights Reserved.